

## PLIA CHAIR

---

Istruzioni per sostituzione schienali e sedili  
*Assembly instruction for back and seat substitution*



# SOSTITUZIONE SCHIENALE

Back substitution

2



Utilizzare una rivettatrice.  
Use a riveter.



Utilizzare un trapano.  
Use a drill.

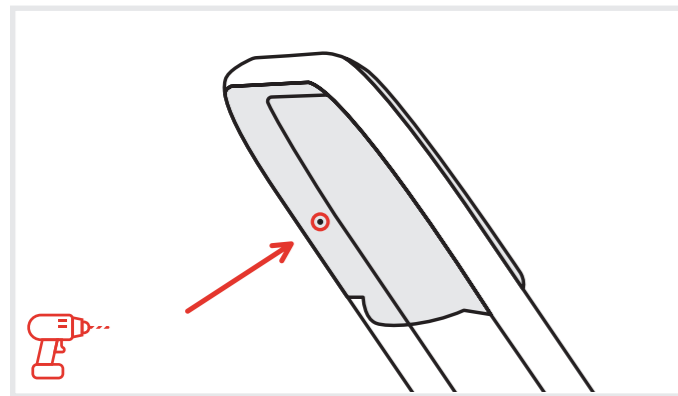
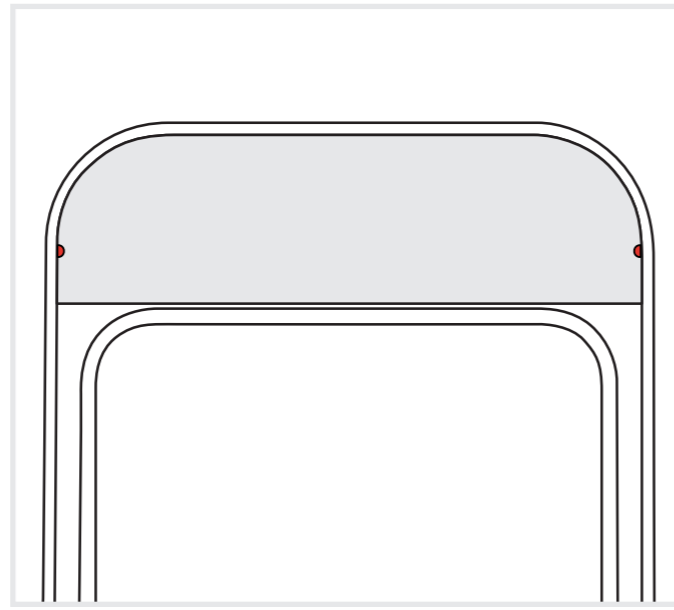
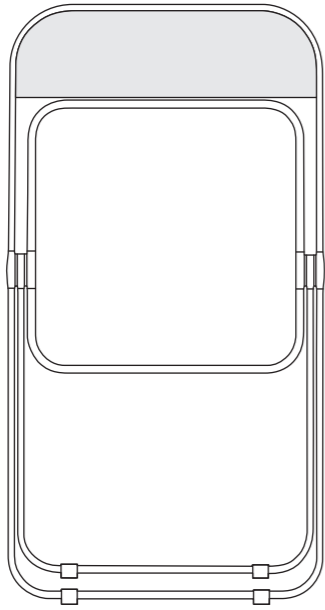

01

Con il trapano forare i rivetti di fissaggio del sedile al tubolare della struttura.

With a drill, pierce the broken rivets from the back.

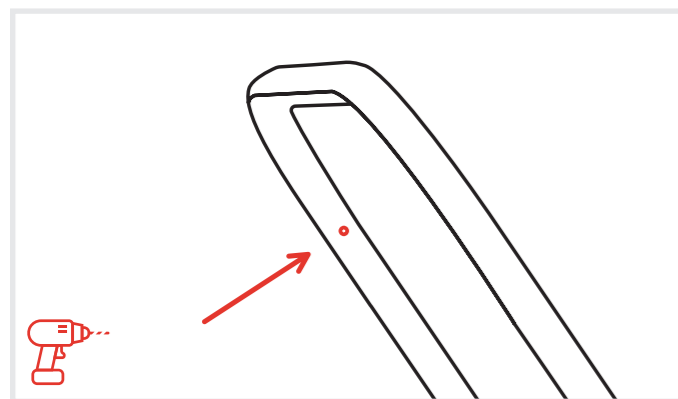

02

Con la punta del trapano pulire anche il foro da eventuali trucioli.

With the drill clean also eventually chips inside the hole.

Posizionare lo schienale di ricambio in modo da metterlo in posizione, facendolo ruotare per la corrispondenza dei fori di fissaggio struttura-schienale.

Place the new back in order to put it in the correct position, and turn it till the correspondence of the fixing holes structure- back.

03

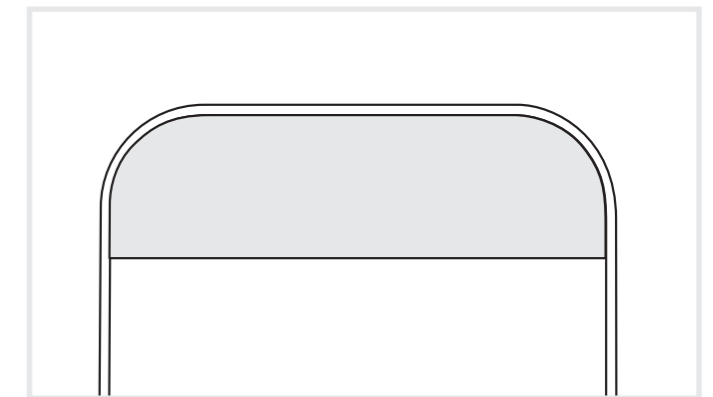
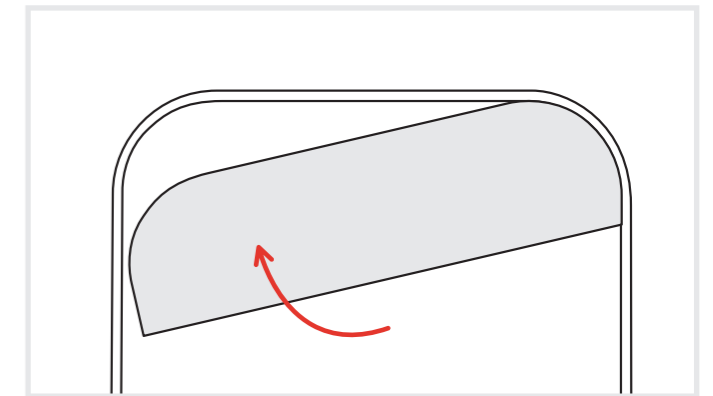

Rivettare il nuovo schienale al tubolare.

Rivet the new back to the tubular of the structure.

04



3

# SOSTITUZIONE SEDILE

## Seat substitution

4



Utilizzare un martello in PVC.  
Use a PVC hammer.



Consigliata pistola termica.  
Recommended a heat gun.



Utilizzare carta vetrata.  
Use sandpaper.



Consigliata colla Araldite.  
Recommended Araldite glue.

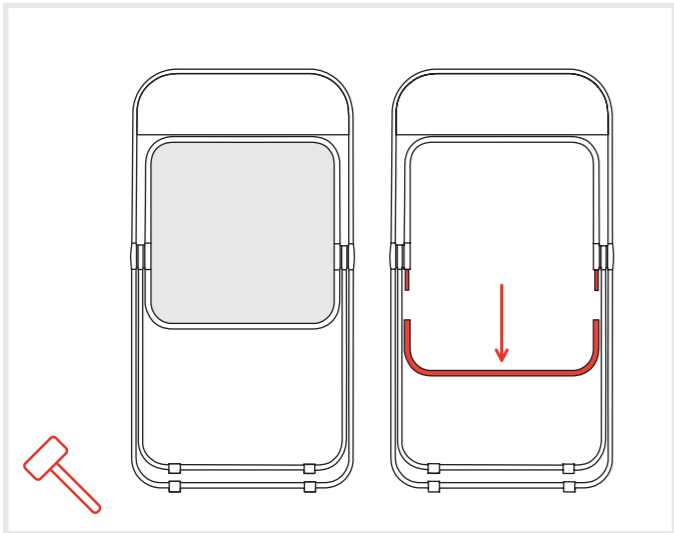
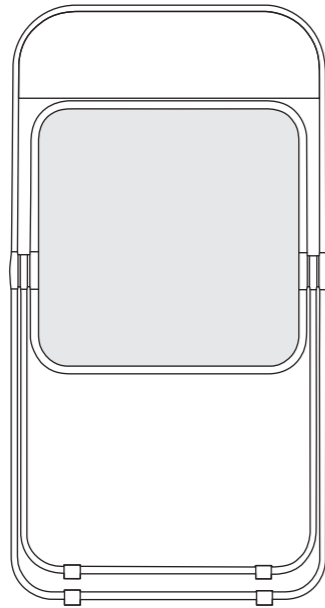

01

Dopo aver rimosso il sedile danneggiato, posizionare chiuso il telaio, per poter rimuovere parte dell'anello di struttura (con martello in PVC).

After removing the damaged seat, put the frame of the chair close, and remove a piece of the seat ring structure (using a PVC hammer).

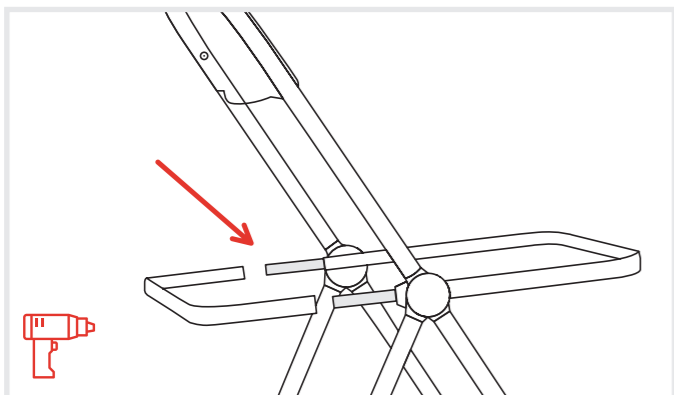

02

Se necessario utilizzare anche una pistola termica per sciogliere la colla dall'innesto (facendo attenzione ai particolari in plastica).

If needed use also a heat gun to melt the old glue from the node (pay attention to the plastic piece).

5

Pulire l'innesto del snodo con carta vetrata.

Clean the joint insert with sandpaper.

03

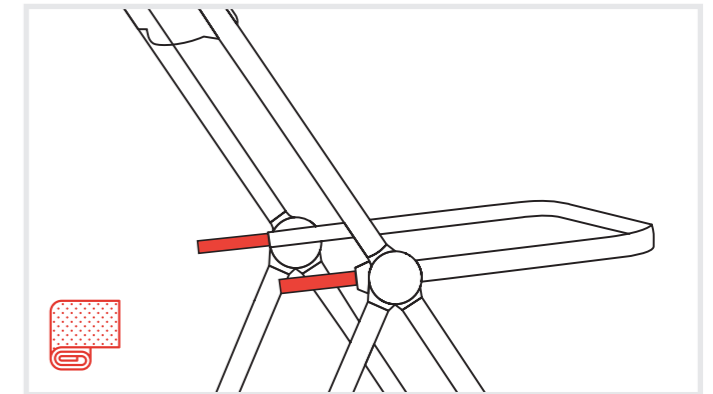

Inserire il nuovo sedile all'interno del semi anello.

Put the new seat inside the half seat structure.

04

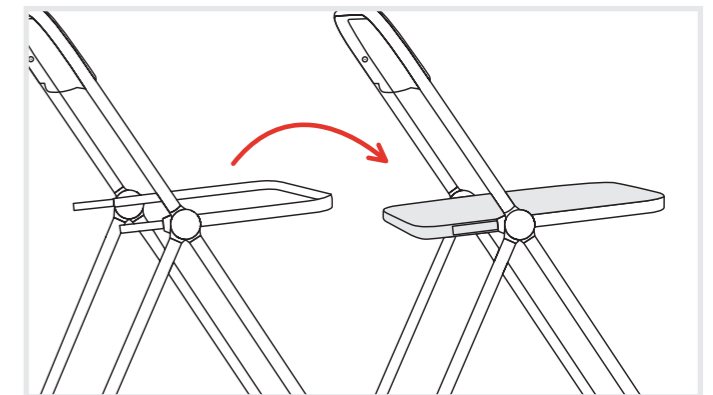

Inserire il semi anello smontato utilizzando un martello in PVC.

Insert the half ring dismantled using a PVC hammer.

05

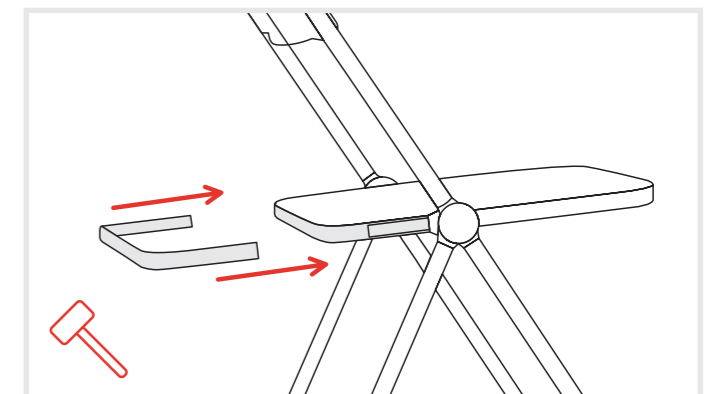

Nel caso in cui l'innesto risulti poco solido, suggeriamo di utilizzare la colla epossidica bicomponente ARALDITE.

In case of a loose connection between pieces, we suggest to use epoxy bi-component ARALDITE glue.

06

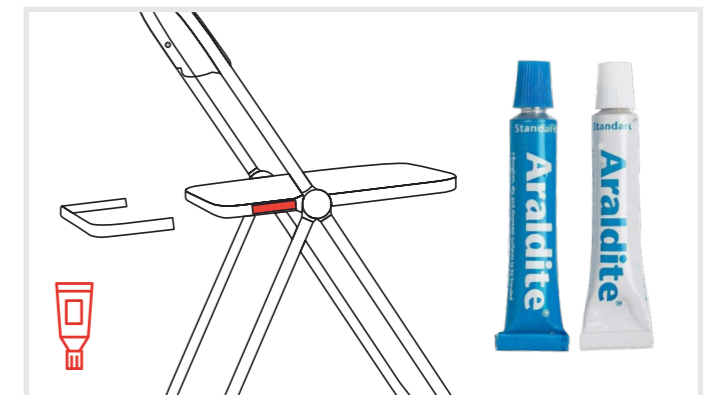



Via Pian di Pan, 61  
33080 Fiume Veneto (PN)  
Italy

T. +39 0434 1605974  
M. +39 340 8376190  
[www.anonimacastelli.com](http://www.anonimacastelli.com)